

	DATE	BY	REVISION
A	10/13/2017	KPV	INITIAL DESIGN
B	11/9/2017	KPV	Additional cutouts added for new part number
C	1/17/2018	KPV	Skewer holes changed to ellipses, Latch arm changed from flat bar
D	2/22/18	Gilgore	Modify skewer retention feature

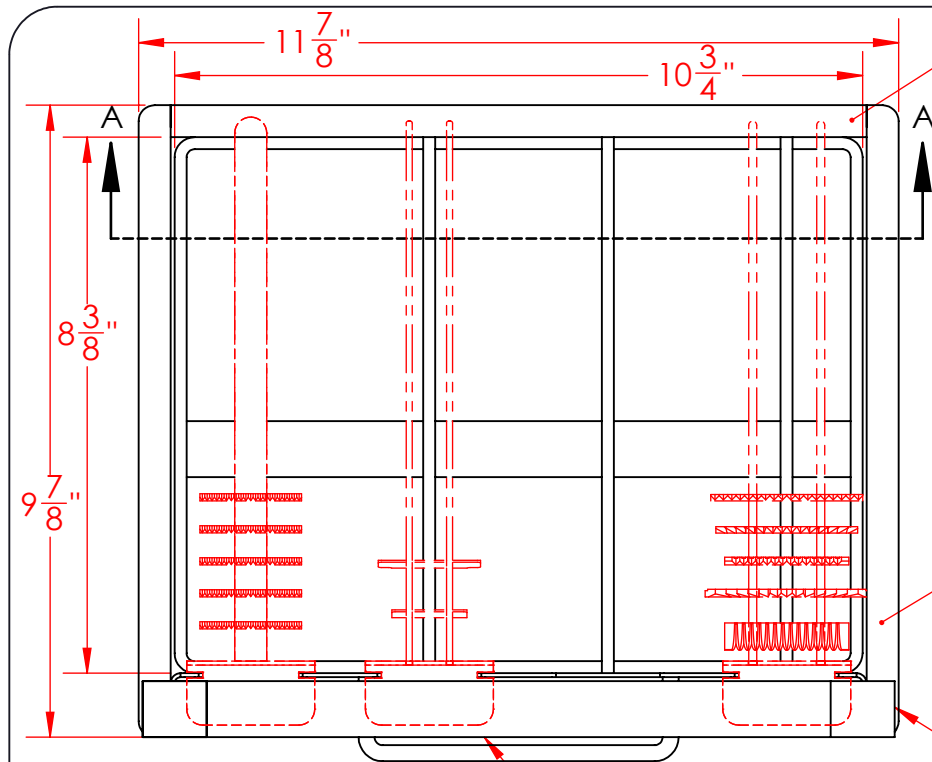

WAHL-121003-LSR-1 - Rev D
 (16 Ga. SHT.)

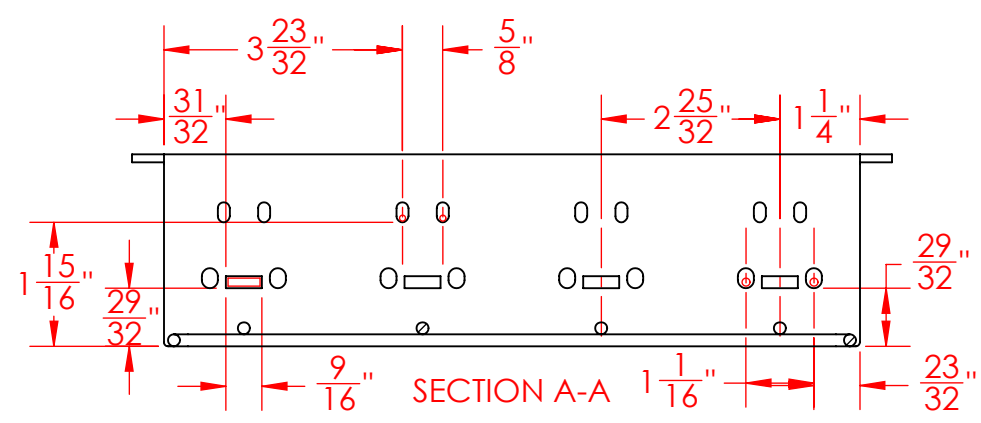

1/8" x 1/2" FLT. BAR
 (2) PLCS.

16 Ga. SHT. LATCH ARM STOP
 WAHL-121003-LSR-4 - Rev D (2)

RIVET
 PART #: 15004
 (2) REQ'D

16 Ga. SHT. FORMED LATCH ARM
 WAHL-121003-LSR-3 - Rev D

WAHL-121003-LSR-2 - Rev D
 (16 Ga. SHT.)

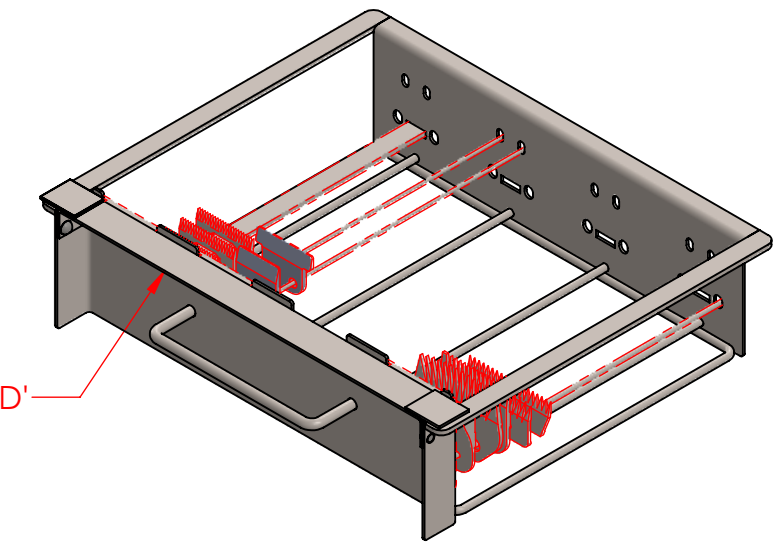
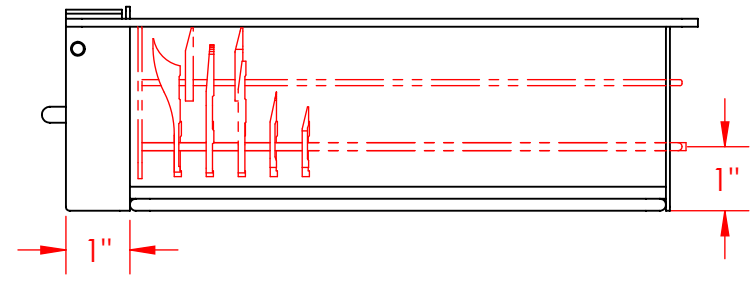
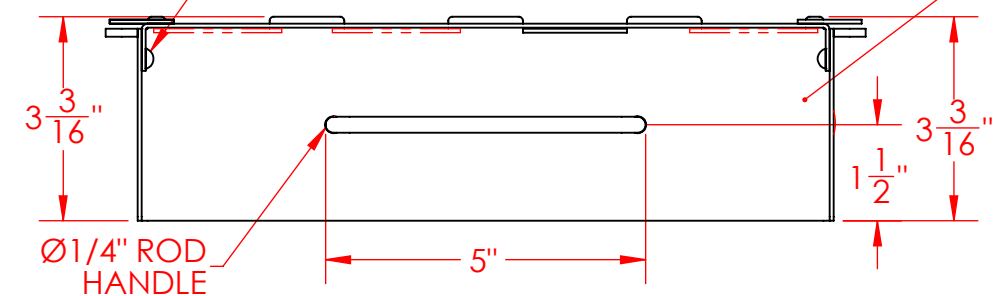

SHOWN w/ (1) WAHL-021102 - Rev A, (1) WAHL-021103 - Rev A, & (1) WAHL-021101 - Rev A PART SKEWERS

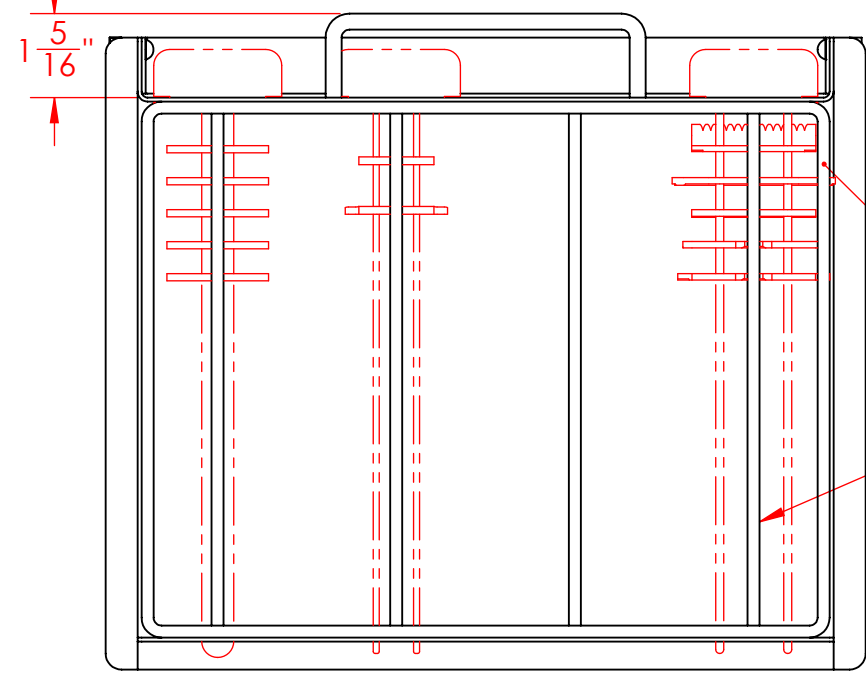
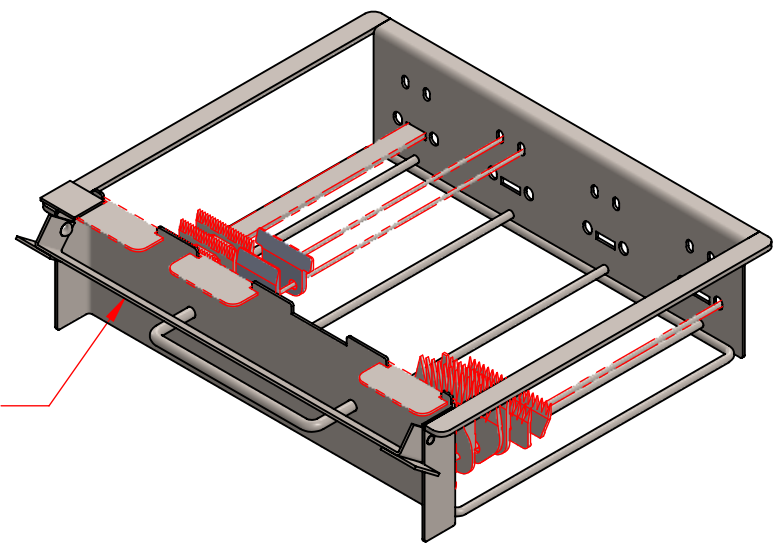

- NOTE:
- ALL ROD TO BE Ø3/16" UNLESS OTHERWISE NOTED
 - WIRE BRUSH TO REMOVE T.I.G. WELD DISCOLORATION

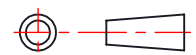
ESTIMATED Wt. 4.0 (lbs.)		 Three M Tool 1038 Elm Street York, PA 17403 Phone: 717-854-6379 Fax: 717-845-5232 www.ThreeMTool.com
MATERIAL: 304 SS		
FINISH: Natural		PART DESCRIPTION Blade Skewer Rack WAHL PART NUMBER WAHL-121003 - REV D
TOLERANCES UNLESS NOTED OTHERWISE ANGLES: ± 2 DEGREES FRACTIONS ± 1/16 .X ± .125 .XX ± .063 .XXX ± .032 THIRD ANGLE PROJECTION		
SCALE: 1:3 SHEET 1 OF 2 <small>THE INFORMATION CONTAINED ON THIS DOCUMENT IS THE INTELLECTUAL PROPERTY OF THREE M TOOL AND MAY NOT BE REPRODUCED OR DISCLOSED WITHOUT PRIOR WRITTEN PERMISSION FROM THREE M TOOL.</small>		REVISION
		SHEET SIZE D B