

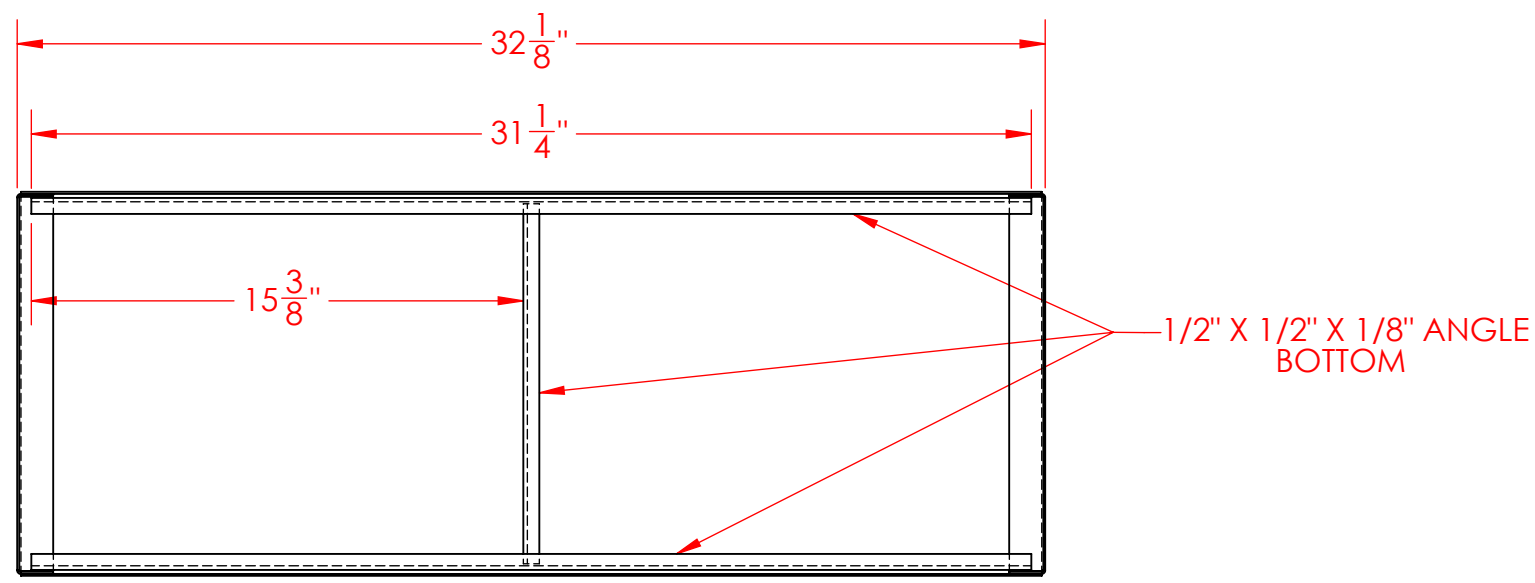

	DATE	BY	REVISION
A	11/10/08	WCB	DRAWN
B	7/15/13	TDB	WIDTH WAS 12 1/8"
C	11/07/13	FCO	MIDDLE SUPPORT ANGLE ON TOP OF BOTTOM ANGLE

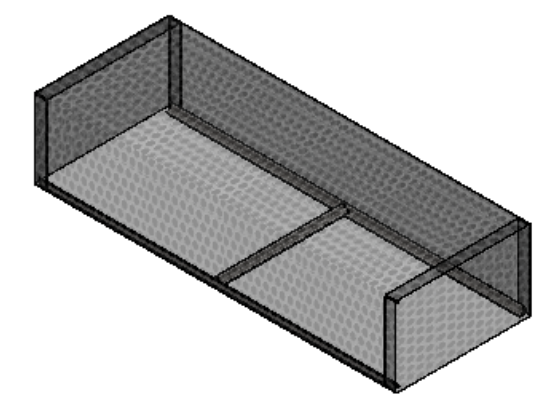
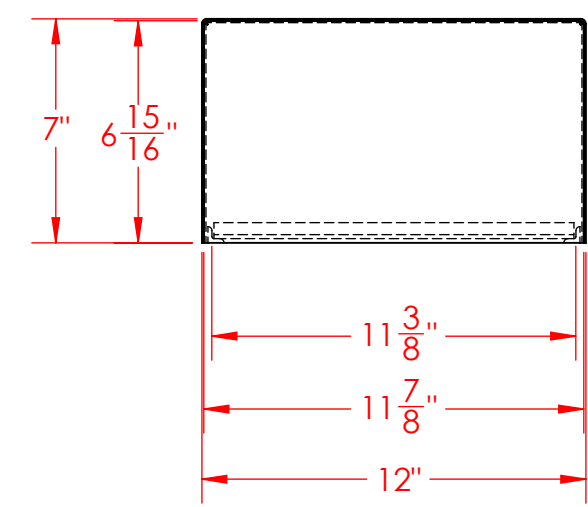
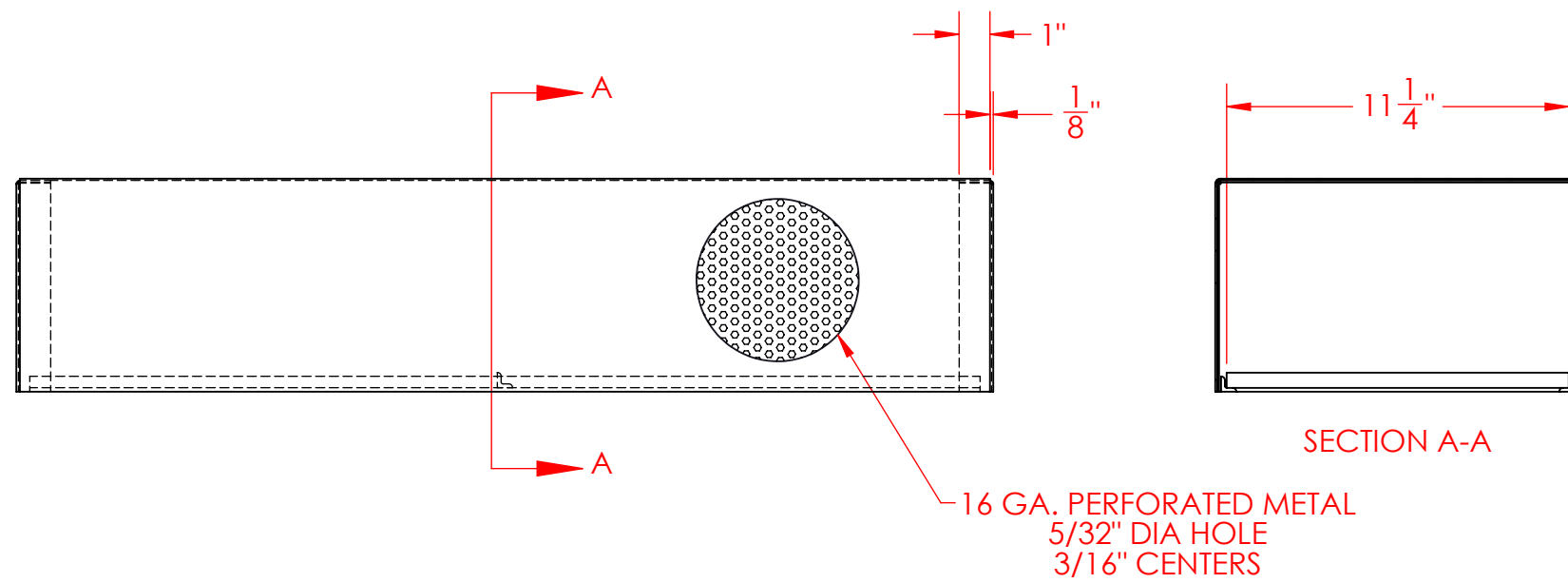
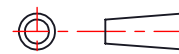

END CAPS TO BE INSIDE NOT OUTSIDE

ESTIMATED Wt. (lbs.): 10.6		 Three M Tool 1038 Elm Street York, PA 17403 Phone: 717-854-6379 Fax: 717-845-5232 www.ThreeMTool.com	
TOLERANCES UNLESS NOTED OTHERWISE ANGLES: ± 2 DEGREES FRACTIONS ± 1/16 .X ± .125 .XX ± .063 .XXX ± .032	MATERIAL: Carbon Steel	PART DESCRIPTION	
	FINISH: Natural	Assy, Pump Suction Filter, Small The Mart Corp. PART NUMBER	
THIRD ANGLE PROJECTION	REVISION	SHEET SIZE	SCALE: NONE
	C	B	SHEET 1 OF 1 CUSTOMER
		TMC-321207	