

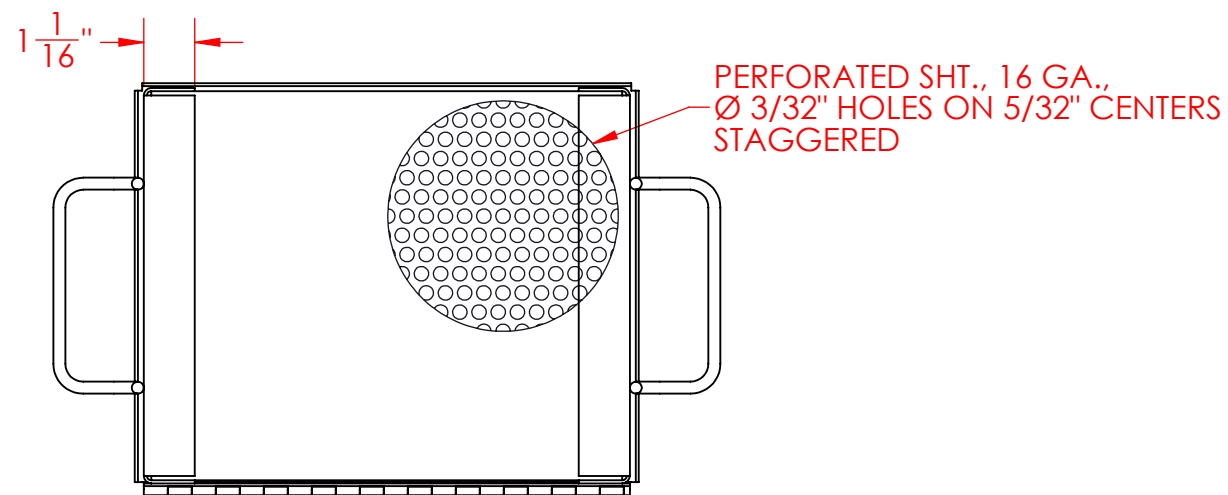

	DATE	BY	REVISION
A	6/1/2020	KPV	INITIAL DESIGN

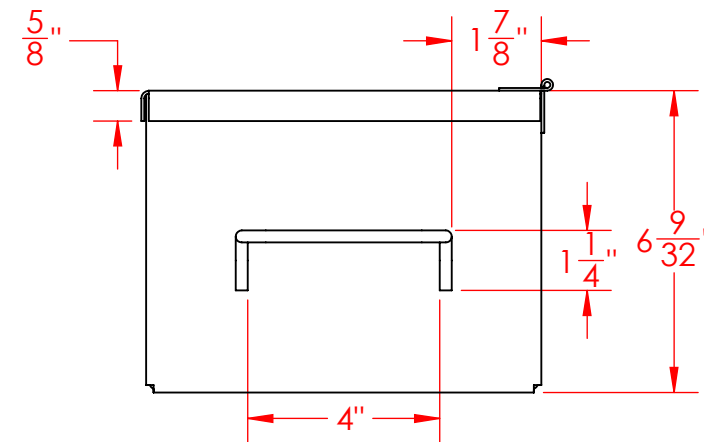
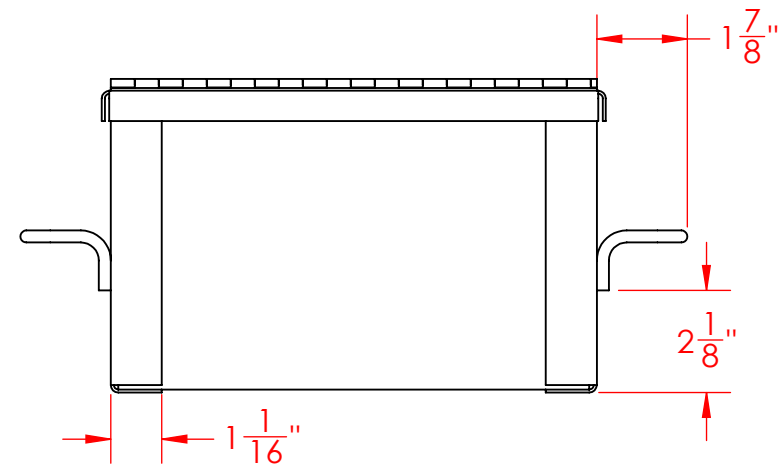
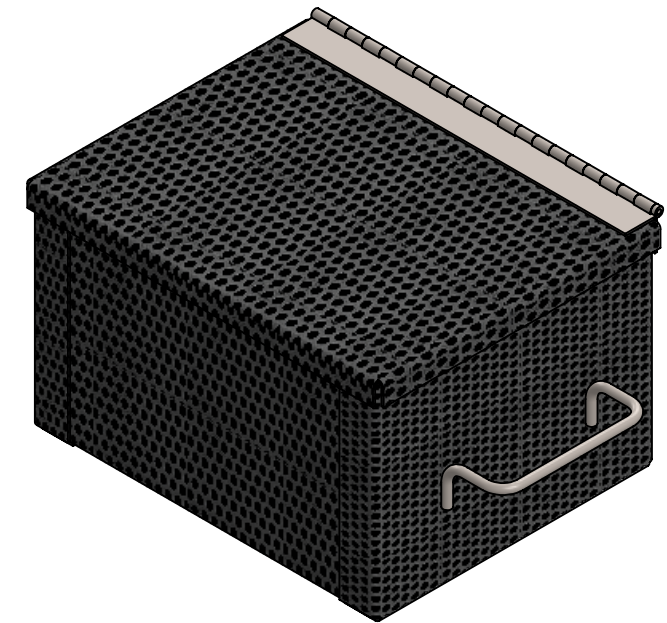
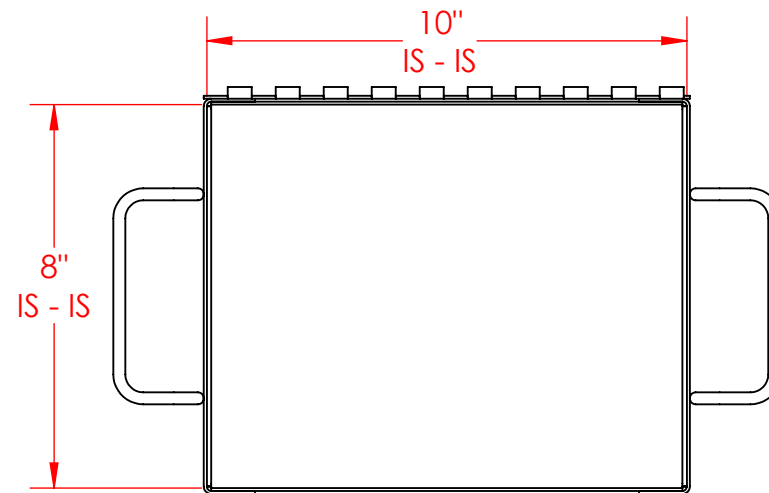
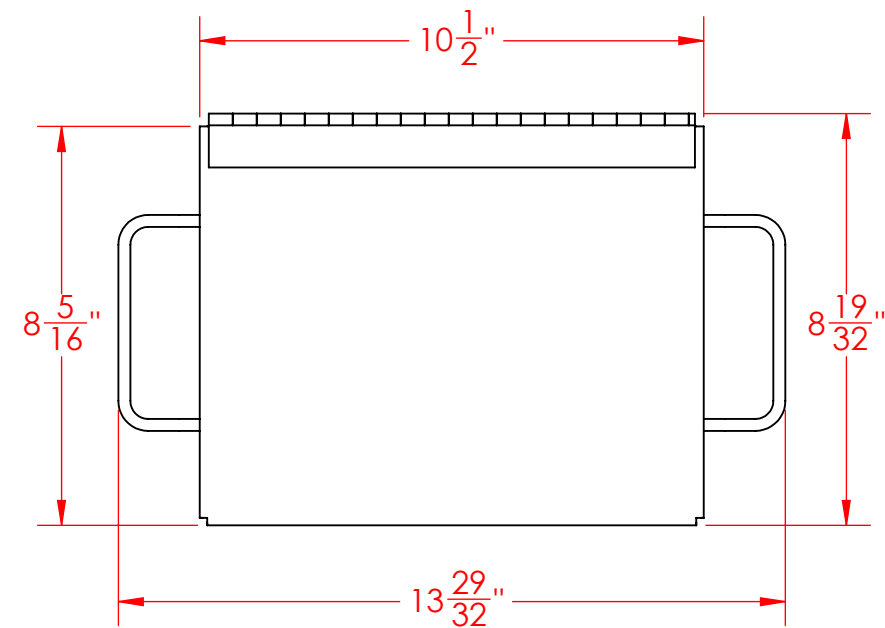

NOTE:

1. ALL ROD TO BE Ø1/4" UNLESS OTHERWISE NOTED
2. INSIDE DIMENSIONS TO BE 10" x 8" x 6"
3. MATERIAL TO BE 3/32" PERF. ON 5/32" CENTERS, 16 Ga., STAGGERED

ESTIMATED Wt. 5.9 (lbs.)		 Three M Tool 1038 Elm Street York, PA 17403 Phone: 717-854-6379 Fax: 717-845-5232 www.ThreeMTool.com
MATERIAL: 304 SS		
FINISH: Natural		PART DESCRIPTION 10 x 8 x 6 Perf. Basket w/ Lid McMaster Carr Supply PART NUMBER MCM-31165K88 - REV A
TOLERANCES UNLESS NOTED OTHERWISE ANGLES: ± 2 DEGREES FRACTIONS ± 1/16 .X ± .125 .XX ± .063 .XXX ± .032		
THIRD ANGLE PROJECTION		SCALE: 1:4 SHEET 1 OF 2 <small>THE INFORMATION CONTAINED ON THIS DOCUMENT IS THE INTELLECTUAL PROPERTY OF THREE M TOOL AND MAY NOT BE COPIED OR DISCLOSED WITHOUT PRIOR WRITTEN PERMISSION FROM THREE M TOOL.</small>
		SHEET SIZE B