

	DATE	BY	REVISION
A	8/19/2019	KPV	INITIAL DESIGN
B	9/4/2019	KPV	Part Orientation Rotated

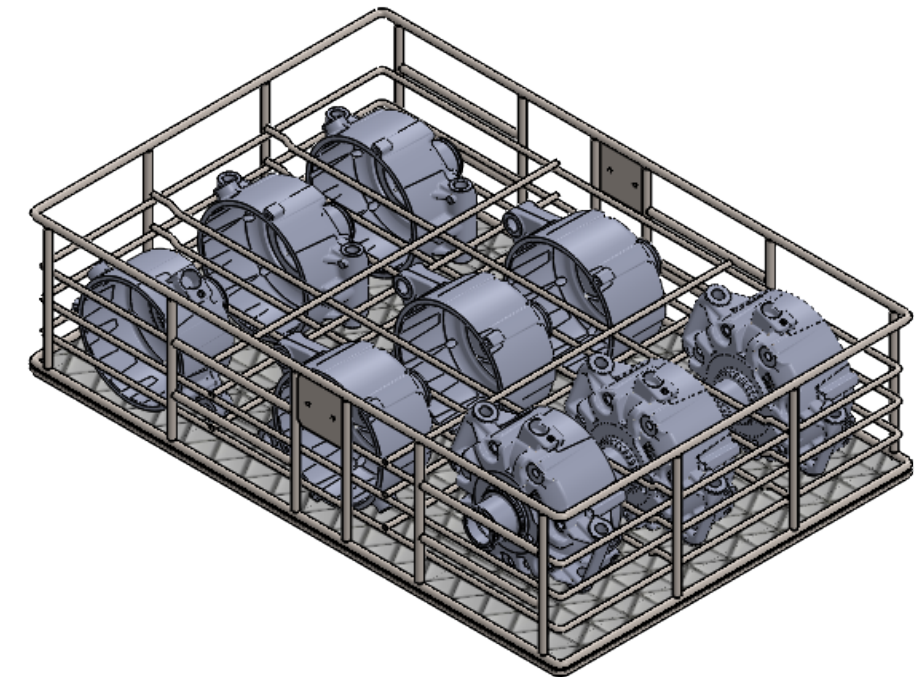

SHOWN w/ (1) T-28, (2) T-29, (3) T-21, & (3) T-23 FRONT HEADS

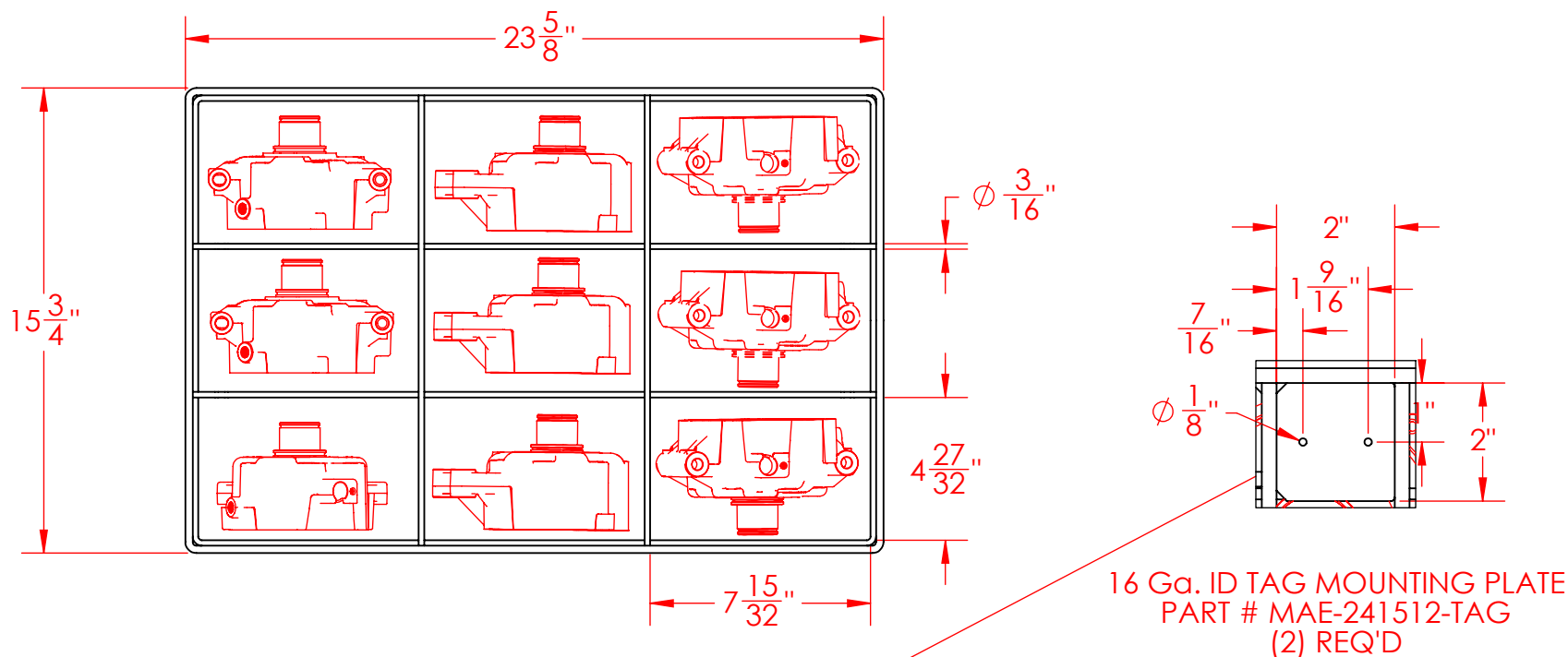
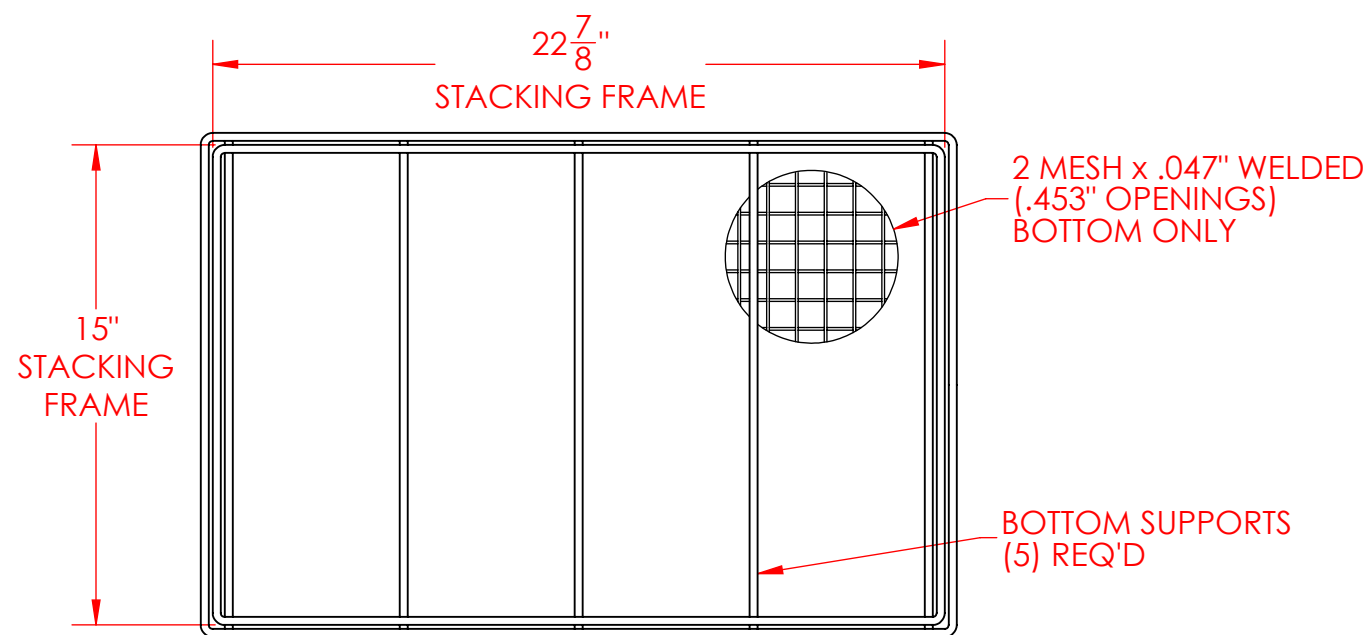
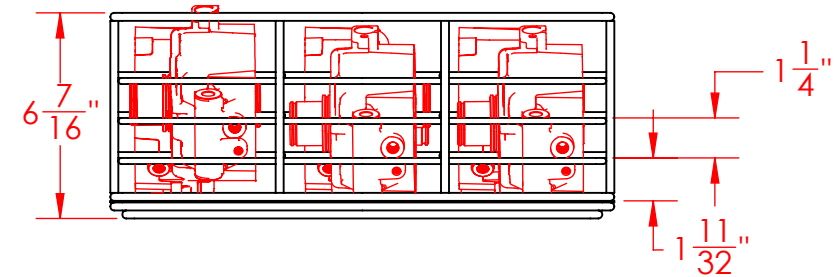
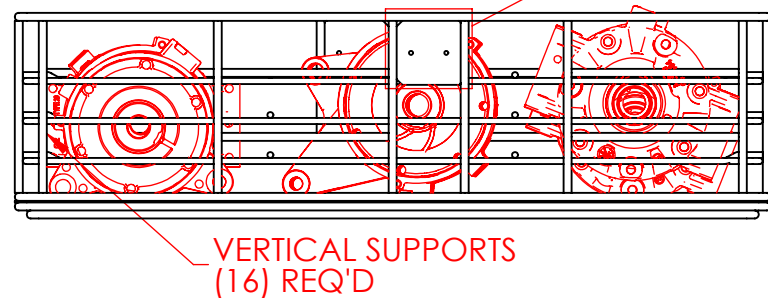

- NOTE:
1. ALL ROD TO BE ϕ 1/4" UNLESS OTHERWISE NOTED
 2. WIRE BRUSH TO REMOVE ALL T.I.G. WELD DISCOLORATION
 3. BASKET IS DESIGNED TO HOLD A MAXIMUM OF (9) CUSTOMER PARTS
 4. GRID FIXTURE REQUIRED
 5. SEE TABLE FOR PART COMPATIBILITY

BASKET PART #	T-21	T-23	T-26	T-27	T-28	T-29	T-30	T-31	T-32	T-33	MAX. QUANTITY
MAE-241521 - Rev B			X	X			X	X	X	X	12
MAE-241522 - Rev B	X	X	X	X	X	X	X	X	X	X	09

ESTIMATED Wt. 12.1 (lbs.)	TMT Three M Tool 1038 Elm Street York, PA 17403 Phone: 717-854-6379 Fax: 717-845-5232 www.ThreeMTool.com
MATERIAL: 304 SS	
FINISH: Natural	PART DESCRIPTION Rectangular Basket with Part Grids Mahle PART NUMBER MAE-241522 - REV B
TOLERANCES UNLESS NOTED OTHERWISE ANGLES: \pm 2 DEGREES FRACTIONS \pm 1/16 .X \pm .125 .XX \pm .063 .XXX \pm .032	
THIRD ANGLE PROJECTION	SCALE: 1:6 SHEET 1 OF 1 REVISION B SHEET SIZE B