

	DATE	BY	REVISION
A	7/6/2017	KPV	INITIAL DESIGN

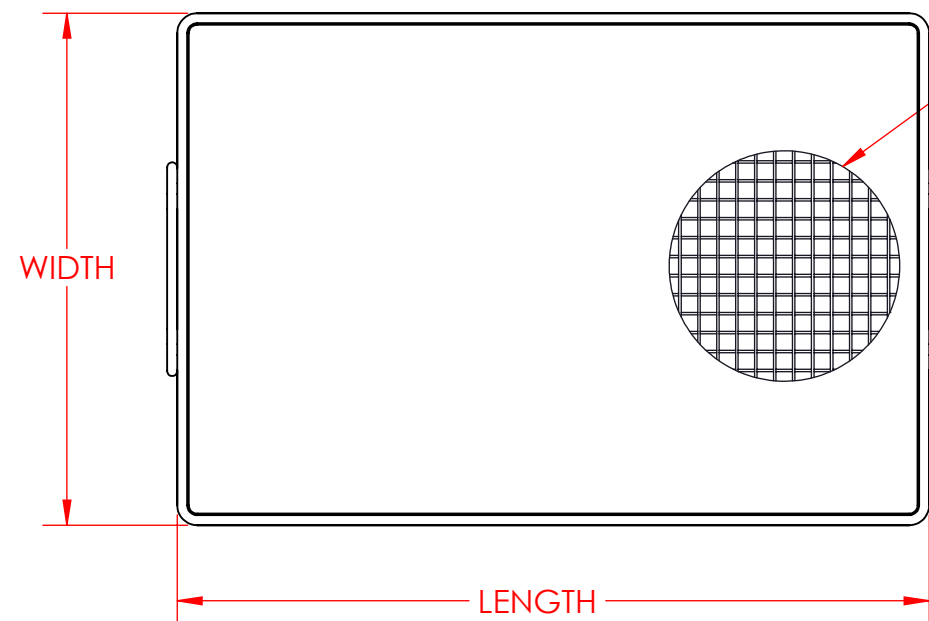

WIRE MESH OR PERFORATED METAL (BOTTOM & SIDES)

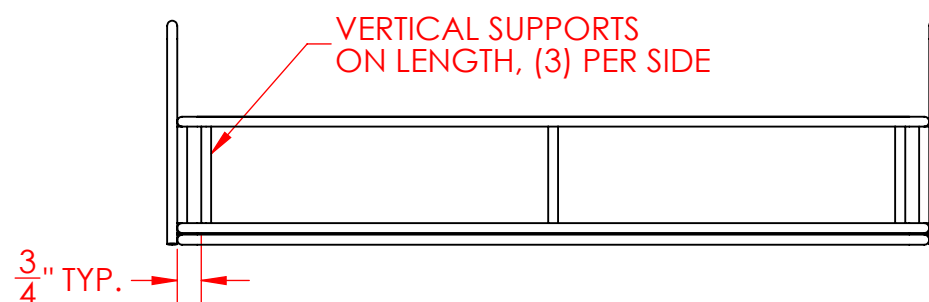
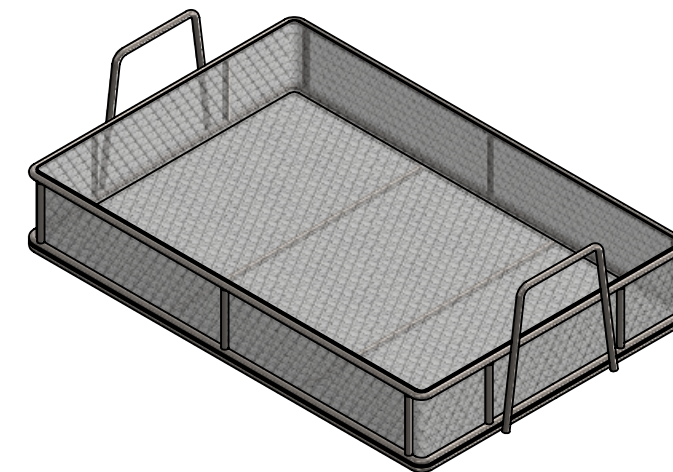

VERTICAL SUPPORTS ON LENGTH, (3) PER SIDE

3/4" TYP.

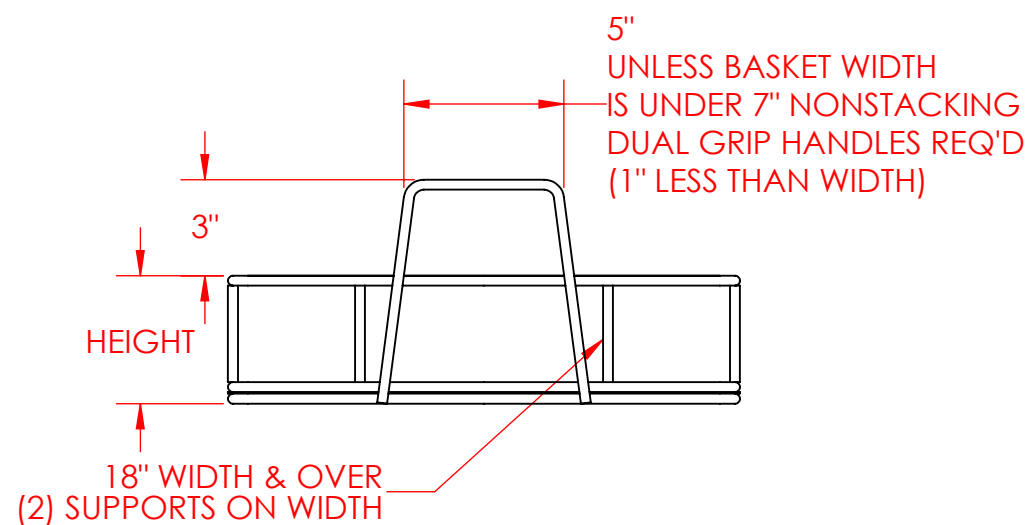

5" UNLESS BASKET WIDTH IS UNDER 7" NONSTACKING DUAL GRIP HANDLES REQ'D (1" LESS THAN WIDTH)

3" HEIGHT

18" WIDTH & OVER (2) SUPPORTS ON WIDTH

BOTTOM SUPPORTS EQUALLY SPACED (2) TYP.

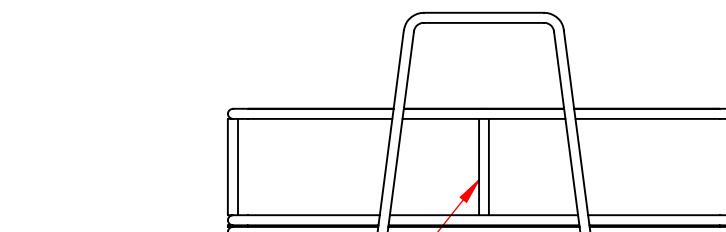
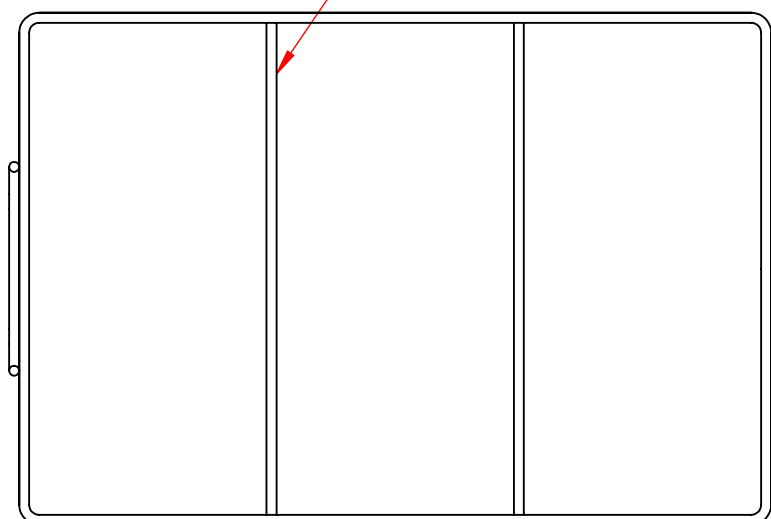

UNDER 18" WIDTH (1) SUPPORT ON WIDTH

Part Number Coding:
TMT-185125050-A04S

"TMT" for mesh, "TMP" for perforated metal

Nominal Outside Length, in inches (185=18-1/2")

Nominal Outside Width, in inches (125=12-1/2")

Nominal Side Wall Height, in inches (050=5")

Handle & Lid Style designation

Mesh or Perf size (04 is 4 Mesh)

Material (S is 304 Stainless Steel Natural Finish)

NOTE:
1. ALL ROD TO BE ϕ 5/16" UNLESS OTHERWISE NOTED

MATERIAL: SEE PART NUMBER

FINISH:SEE PART NUMBER

TOLERANCES UNLESS NOTED OTHERWISE
ANGLES: \pm 2 DEGREES
FRACTIONS \pm 1/16
.X \pm .125
.XX \pm .063
.XXX \pm .032

SCALE: 1:6
SHEET 1 OF 1

THE INFORMATION CONTAINED ON THIS DOCUMENT IS THE INTELLECTUAL PROPERTY OF THREE M TOOL AND MAY NOT BE COPIED OR DISCLOSED WITHOUT PRIOR WRITTEN PERMISSION FROM THREE M TOOL.

REVISION SHEET SIZE

THIRD ANGLE PROJECTION



A

B

TMT Three M Tool
1038 Elm Street
York, PA 17403
Phone: 717-854-6379
Fax: 717-845-5232
www.ThreeMTool.com

PART DESCRIPTION
Rectangular Basket, Stacking Dual Grip Length: 18" - 23 1/2"
Three M Tool
PART NUMBER
TMT-REC-A-DG-18-23.5