

	DATE	BY	REVISION
A	10/4/2016	KPV	INITIAL DESIGN
B	10/6/2016	KPV	(2) UPRIGHTS SHORTENED BY 1"
C	10/10/2016	KPV	(2) UPRIGHTS ANGLED AT 10°, SINGLE HOLES ADDED TO MOUNTING TABS
D	11/17/2016	KPV	UPRIGHTS SPACED 3/32" FURTHER APART, UPRIGHT CAPS ADDED
E	8/5/2019	KPV	Notch added to bottom frame, (1) up right moved off of frame

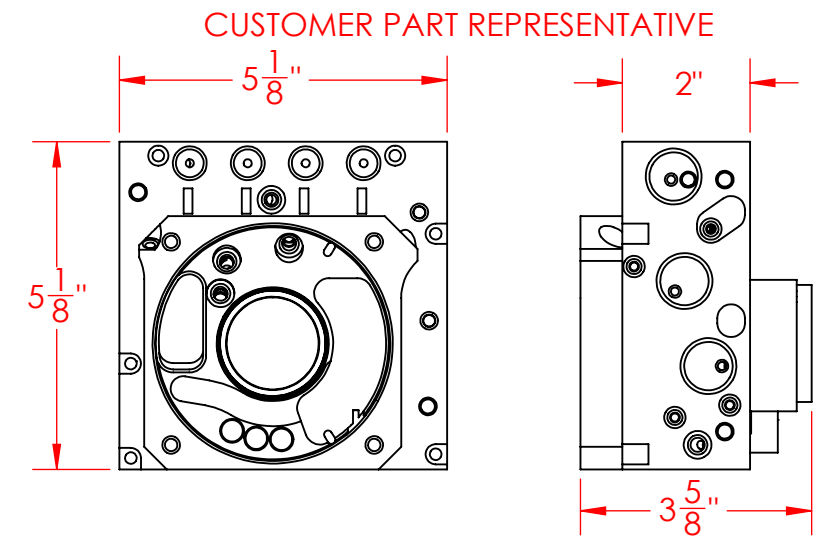
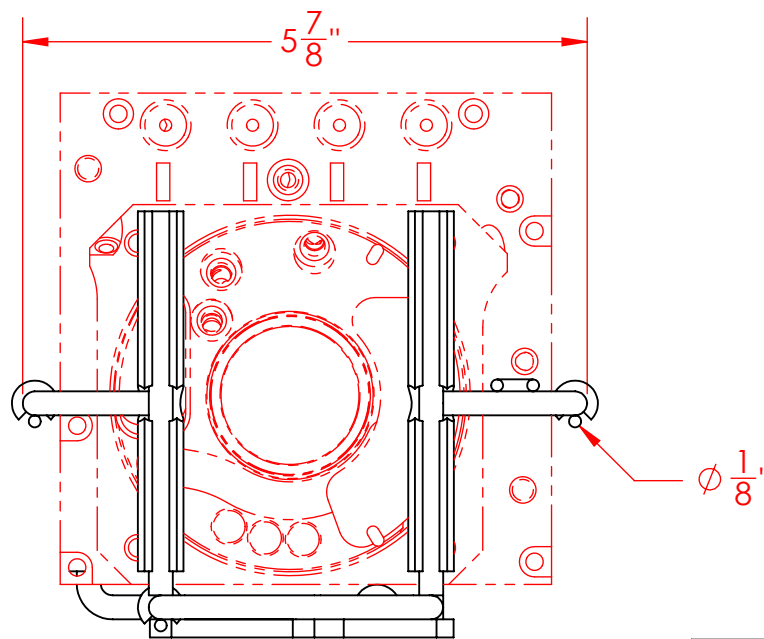
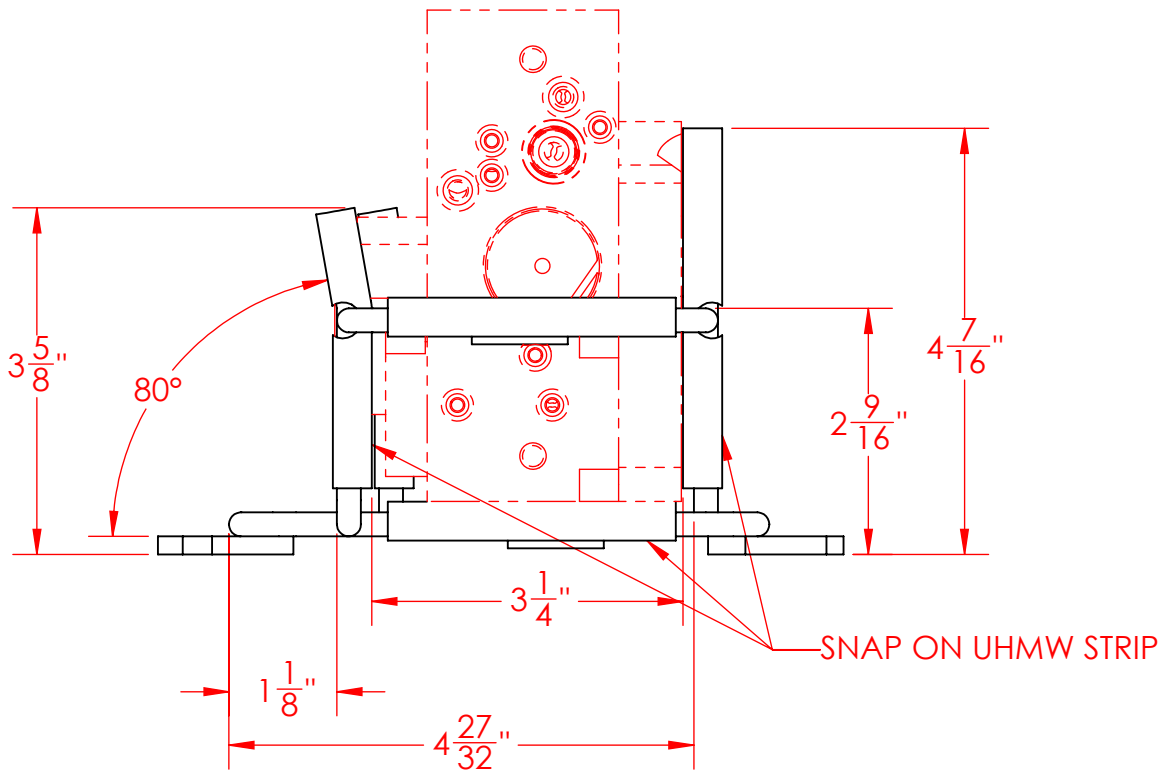
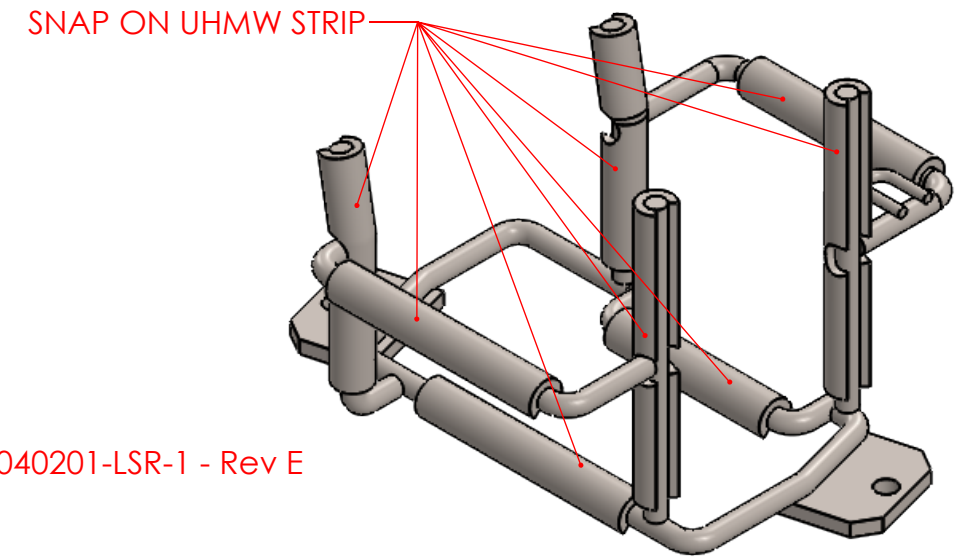
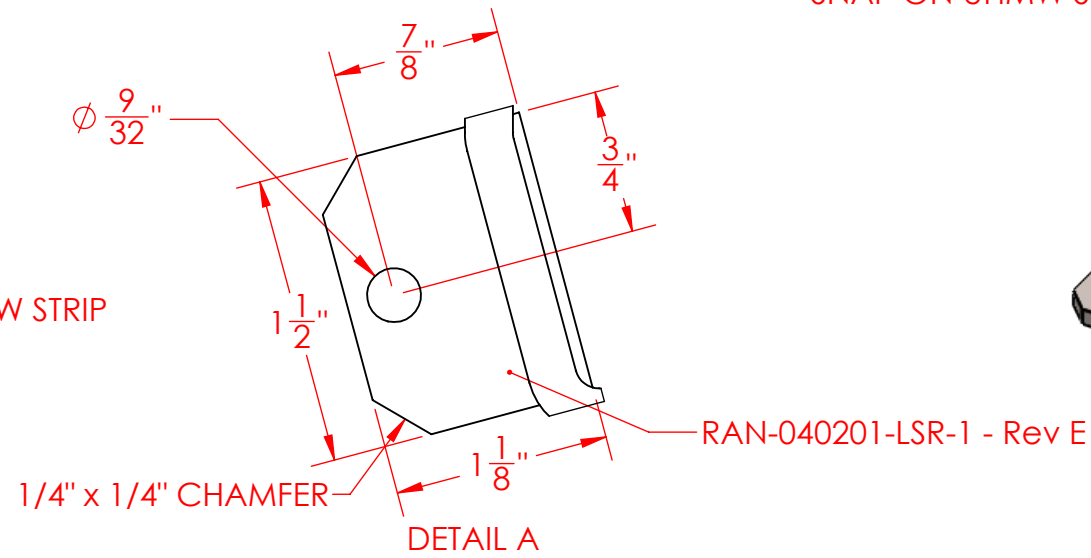
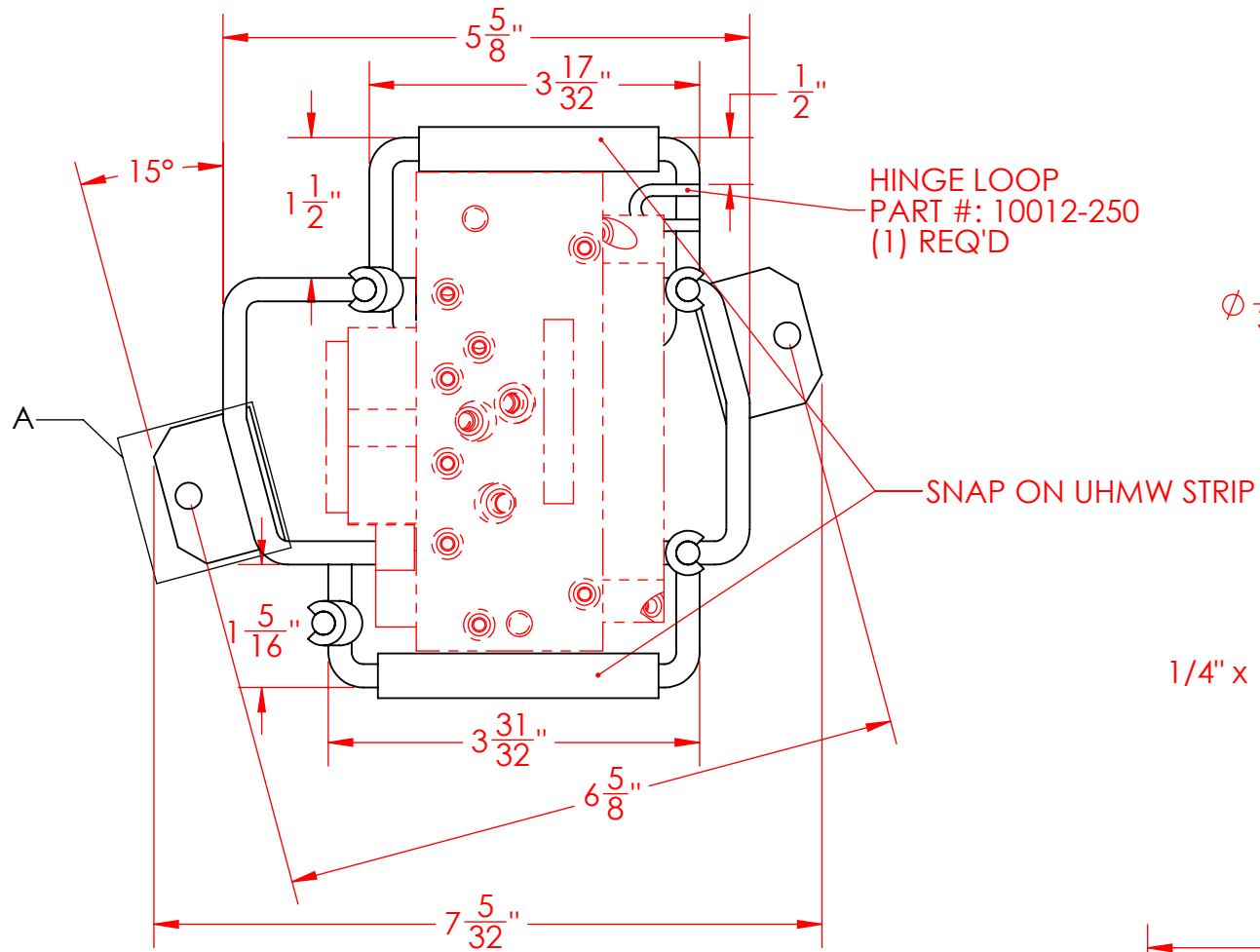

- NOTE:
1. ALL ROD TO BE Ø 1/4" UNLESS OTHERWISE NOTED
 2. WIRE BRUSH TO REMOVE T.I.G. WELD DISCOLORATION
 3. GRID FIXTURE REQ'D

ESTIMATED Wt. 12.5 (lbs.)		TMT Three M Tool 1038 Elm Street York, PA 17403 Phone: 717-854-6379 Fax: 717-845-5232 www.ThreeMTool.com
MATERIAL: 304 SS		
FINISH: Natural		PART DESCRIPTION OPH Fixture Ransohoff PART NUMBER RAN-040202 - REV E
TOLERANCES UNLESS NOTED OTHERWISE ANGLES: ± 2 DEGREES FRACTIONS ± 1/16 .X ± .125 .XX ± .063 .XXX ± .032		
SCALE: 1:2 SHEET 1 OF 4	REVISION	SHEET SIZE
THIRD ANGLE PROJECTION	E	B

	DATE	BY	REVISION
A	10/4/2016	KPV	INITIAL DESIGN
B	10/6/2016	KPV	(2) UPRIGHTS SHORTENED BY 1"
C	10/10/2016	KPV	(2) UPRIGHTS ANGLED AT 10°, SINGLE HOLES ADDED TO MOUNTING TABS
D	11/17/2016	KPV	UPRIGHTS SPACED 3/32" FURTHER APART, UPRIGHT CAPS ADDED
E	8/5/2019	KPV	Notch added to bottom frame, (1) up right moved off of frame

SNAP ON UHMW STRIP

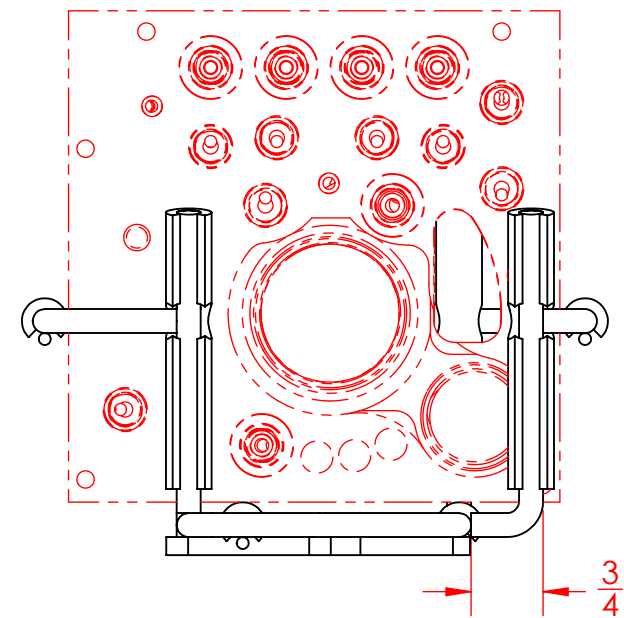
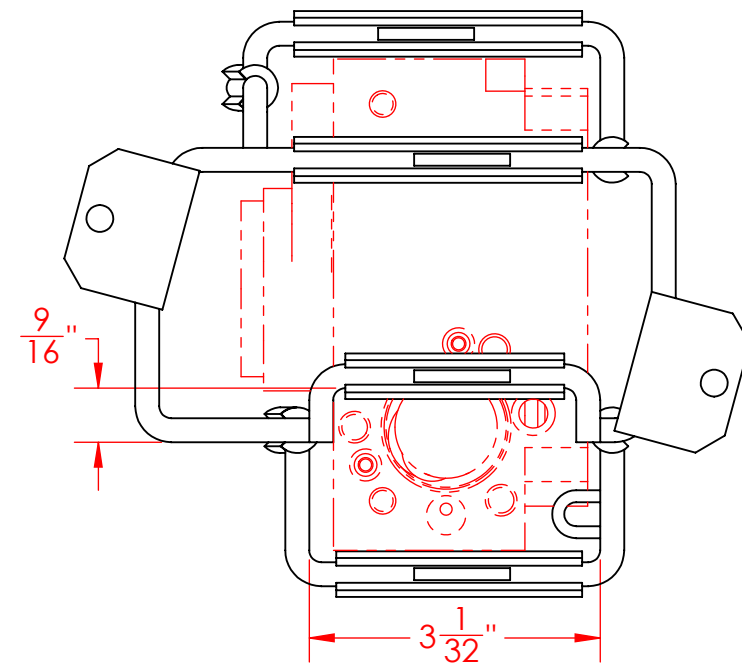
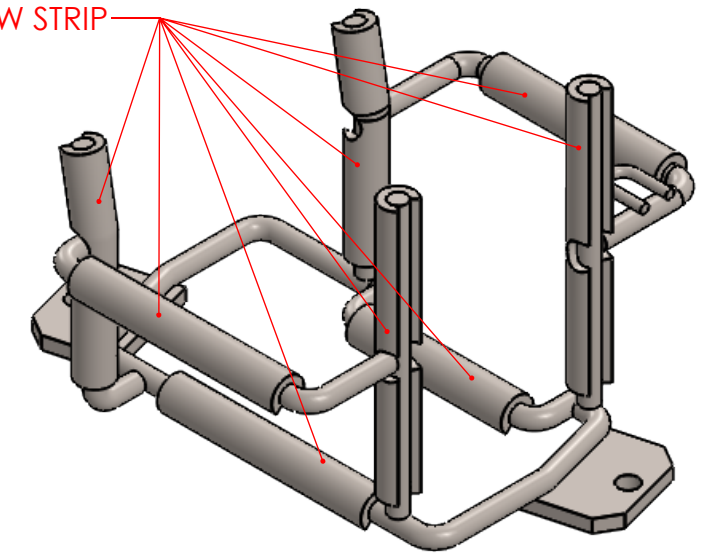

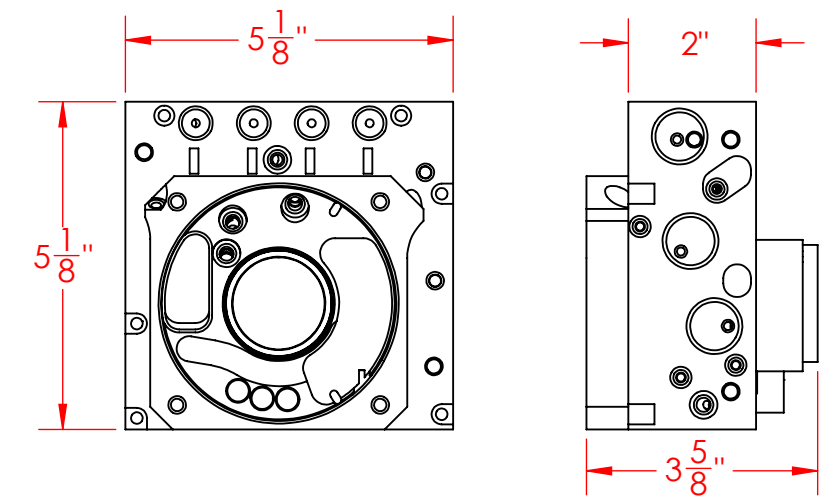

CUSTOMER PART REPRESENTATIVE



NOTE:

1. ALL ROD TO BE ϕ 1/4" UNLESS OTHERWISE NOTED
2. WIRE BRUSH TO REMOVE T.I.G. WELD DISCOLORATION
3. GRID FIXTURE REQ'D

ESTIMATED Wt. 12.5 (lbs.)		 Three M Tool 1038 Elm Street York, PA 17403 Phone: 717-854-6379 Fax: 717-845-5232 www.ThreeMTool.com	
MATERIAL: 304 SS			
FINISH: Natural			
TOLERANCES UNLESS NOTED OTHERWISE ANGLES: \pm 2 DEGREES FRACTIONS \pm 1/16 .X \pm .125 .XX \pm .063 .XXX \pm .032	SCALE: 1:2 SHEET 2 OF 4 <small>THE INFORMATION CONTAINED ON THIS DOCUMENT IS THE INTELLECTUAL PROPERTY OF THREE M TOOL AND MAY NOT BE COPIED OR DISCLOSED WITHOUT PRIOR WRITTEN PERMISSION FROM THREE M TOOL.</small>	PART DESCRIPTION	
THIRD ANGLE PROJECTION 	REVISION E	SHEET SIZE B	OPH Fixture Ransohoff PART NUMBER RAN-040202 - REV E