

	DATE	BY	REVISION
A	04/07/04		DRAWN
C	10/7/13	TBD	WAS AUTOCAD
C	12/10/15	Gilgore	Updated to match current production

HANDLE BRACKET (2)

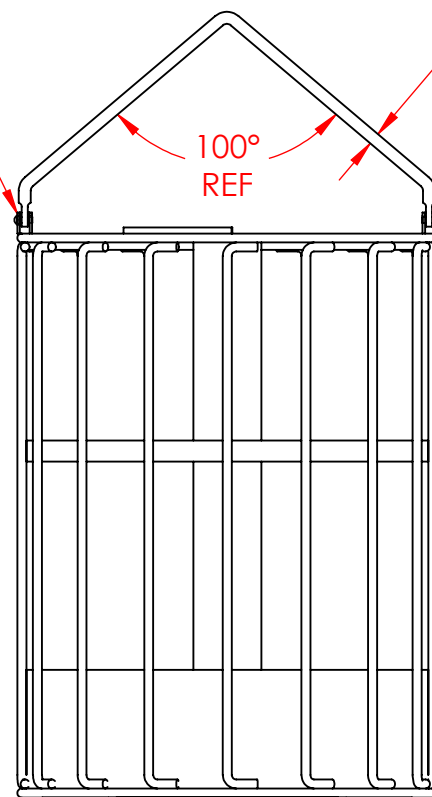

$\phi \frac{1}{2}$ " ROD

$\phi \frac{1}{4}$ " RIVET (2)

SWINGING HANDLE

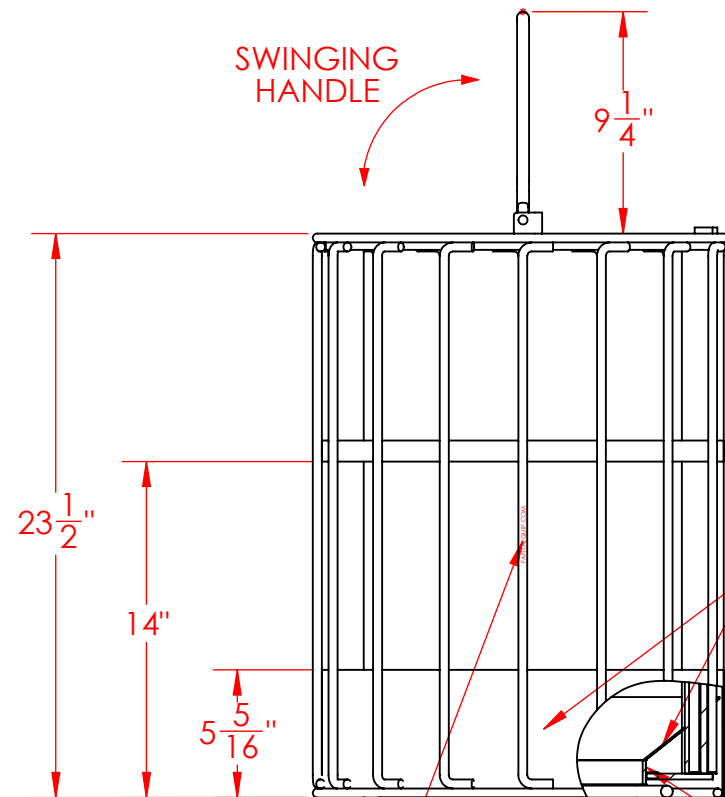

ANGLE TO BE CAPPED WITH 16 GA SHEET

2" x 2" x  $\frac{1}{8}$ " ANGLE (2)

$\frac{1}{8}$ " x  $\frac{1}{2}$ " FLAT BAR INSIDE AT TOP

$\frac{7}{8}$ " WIDE 16 GA. SHEET METAL BAND OUTSIDE MESH

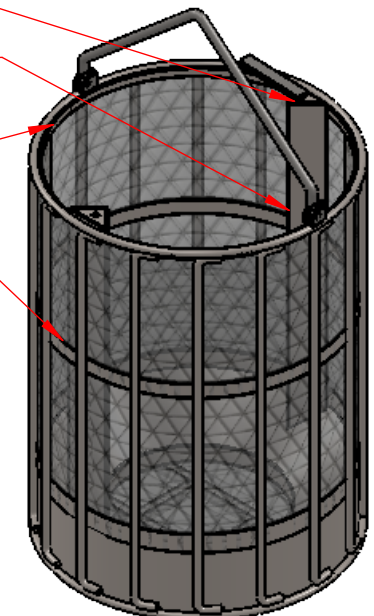

FUNNEL & OUTER SKIRT TO BE 16 Ga

$\frac{1}{8}$ " x 1" FLAT BAR BASE OF FUNNEL

MARK (1) VERTICAL SUPPORT WITH 'FANTAEQUIP.COM' STAMP  
 \*\* DO NOT MARK WITH 'ThreeMTool.com' STAMP\*\*

NOTE:  
 1. ALL ROD TO BE  $\phi \frac{3}{8}$ " UNLESS OTHERWISE NOTED

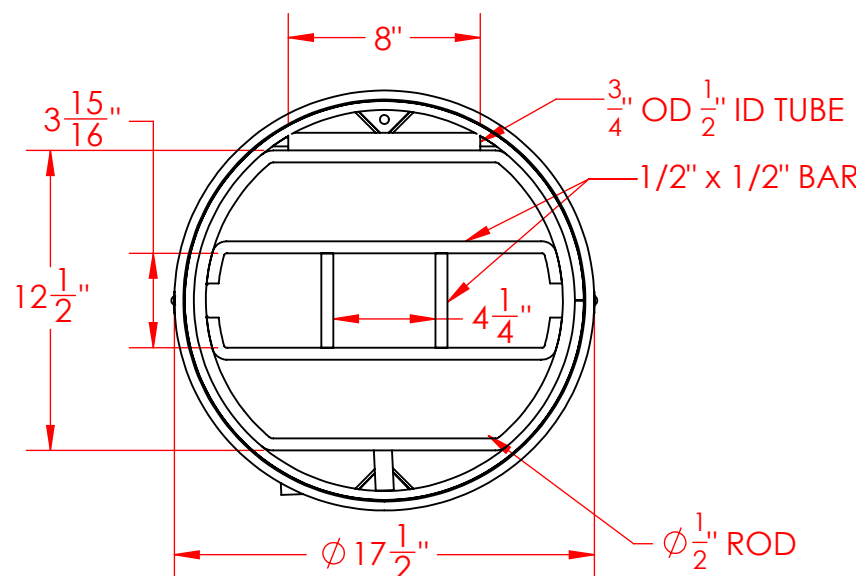

NEW HOLLAND PART #	MATERIAL & MESH
9803995	CS 4 MESH x .080 (.170 OPENING)
9803996	CS 10 MESH x .047 (.053 OPENING)
9803997	SS 4 MESH x .080 (.170 OPENING)
9803998	SS 10 MESH x .047 (.053 OPENING)

ESTIMATED Wt. (lbs.): 76.5	
TOLERANCES UNLESS NOTED OTHERWISE ANGLES: $\pm 2$ DEGREES FRACTIONS $\pm 1/16$ .X $\pm .125$ .XX $\pm .063$ .XXX $\pm .032$	MATERIAL: See Chart FINISH: Natural
THIRD ANGLE PROJECTION	REVISION SHEET SIZE
	C B

**TMT** Three M Tool  
 1038 Elm Street  
 York, PA 17403  
 Phone: 717-854-6379  
 Fax: 717-845-5232  
 www.ThreeMTool.com

PART DESCRIPTION		SCALE: NONE
Spin Dryer Basket with Drop Bottom		SHEET 1 OF 1 CUSTOMER
New Holland		
PART NUMBER	NH-1824-DB	