

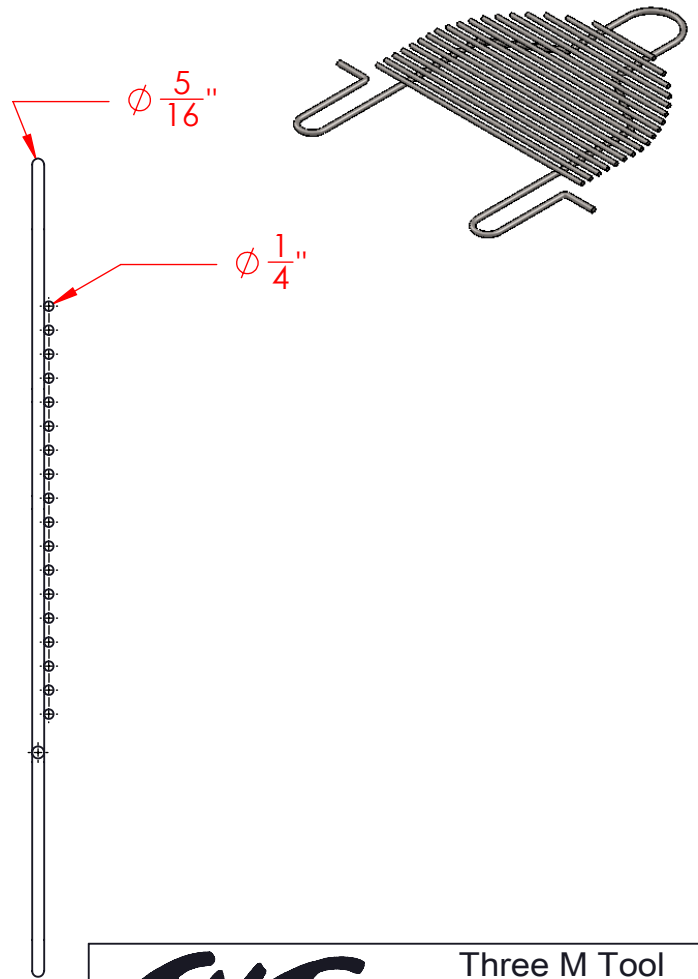

	DATE	BY	REVISION
D	11/04/08	wcb	DRAWN

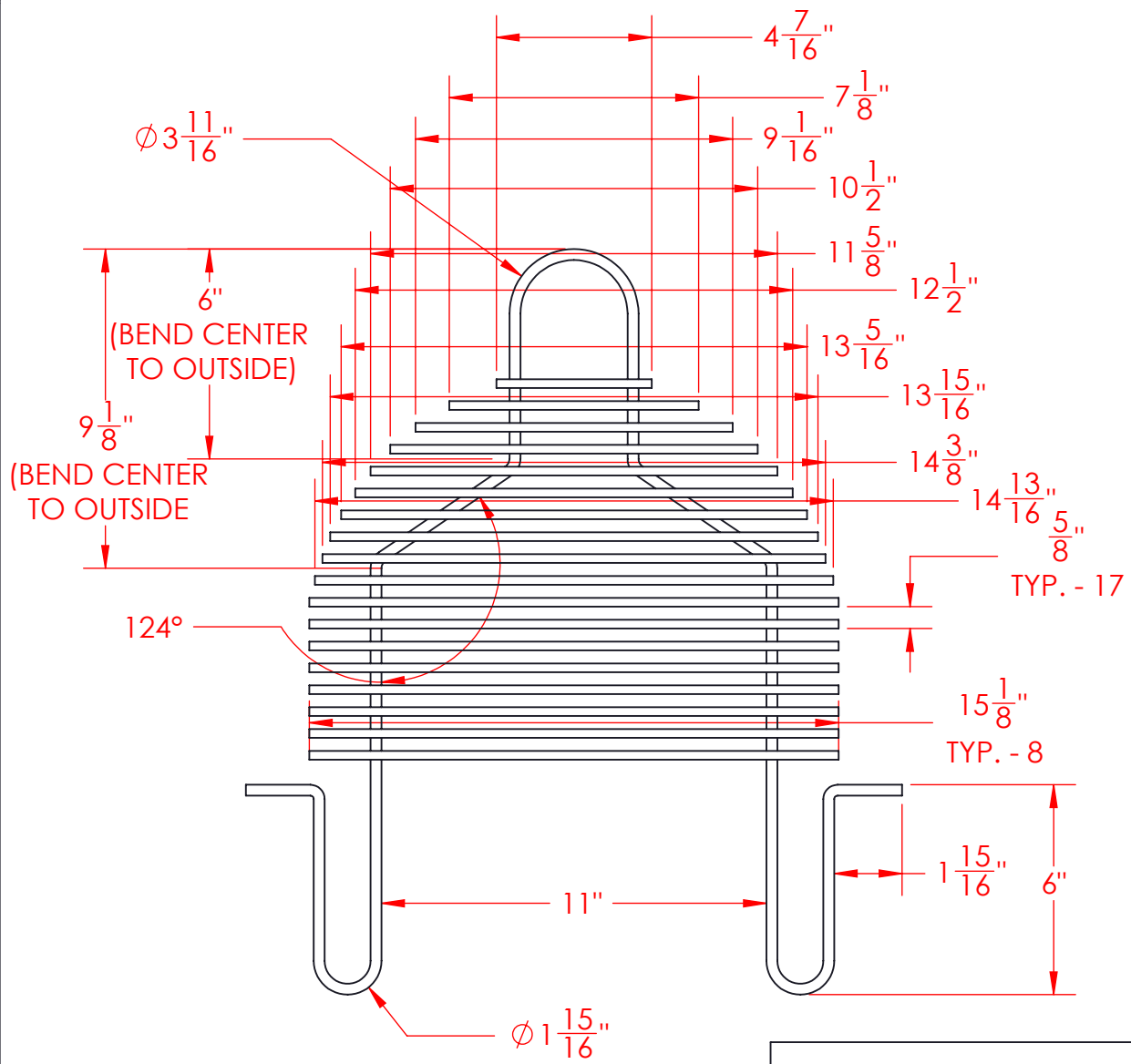

NOTE:
 1) ALL ROD TO BE 5/16" DIA UNLESS NOTED OTHERWISE
 2) ELECTROPOLISH AFTER FABRICATION
 3) GRID FIXTURE REQUIRED

ESTIMATED Wt.: 4.75 lbs.	
TOLERANCES UNLESS NOTED OTHERWISE ANGLES: ± 2 DEGREES FRACTIONS ± 1/16 .X ± .125 .XX ± .063 .XXX ± .032	MATERIAL: 304 SS FINISH: Electro Polish
THIRD ANGLE PROJECTION 	REVISION D
	SHEET SIZE A



Three M Tool
 1038 Elm Street
 York, PA 17403
 Phone: 717-854-6379
 Fax: 717-845-5232
 www.ThreeMTool.com

Grill Rack, Phoenix
 Fire By Design

PART NUMBER
FBD-2019-3

SCALE: NONE
 SHEET 1 OF 1