

	DATE	BY	REVISION
A	06/25/12	FCO	DRAWN
B	06/25/12	FCO	MOVED ROD TO OUTSIDE SCREEN
C	11/14/12	FCO	UPDATED MATERIAL
D	9/2/2020	KPV	Material Table Added

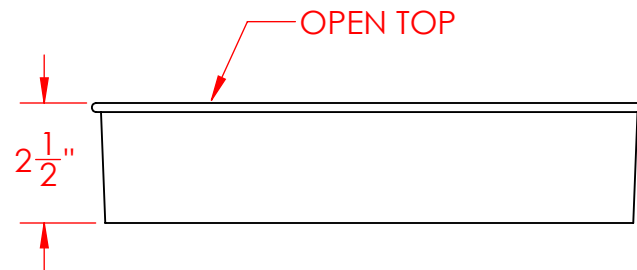
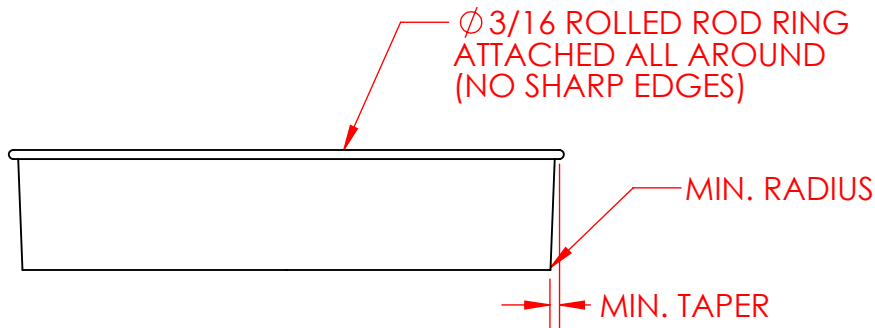
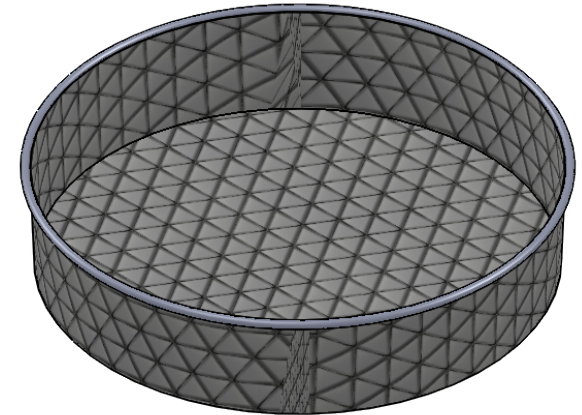
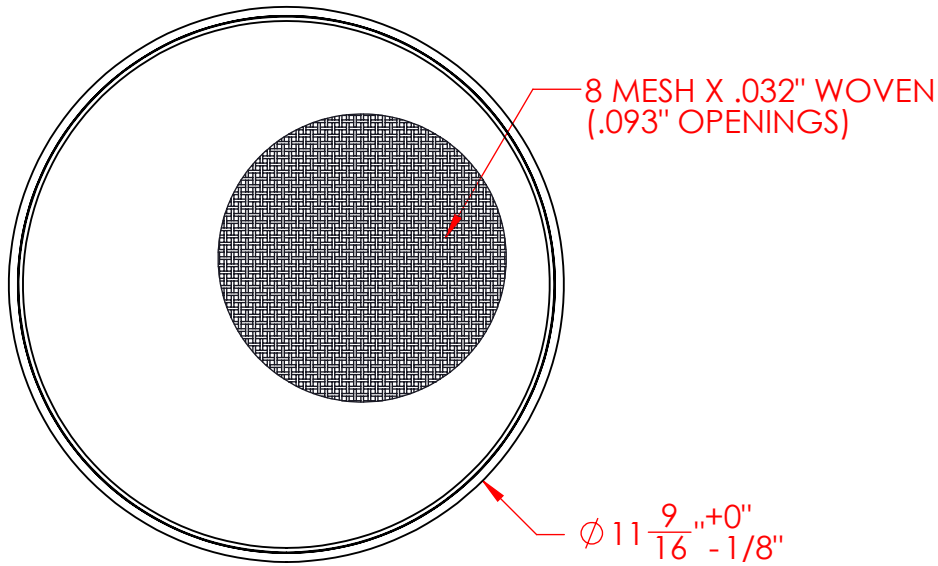

NOTE:  
1) ALL ROD TO BE  $\phi 3/16$ " UNLESS OTHERWISE NOTED

PART NUMBER	MATERIAL
EAE-739041-CS	Carbon Steel
EAE-739041-SS	304 SS

ESTIMATED Wt.: 0.12 lbs.	
TOLERANCES UNLESS NOTED OTHERWISE ANGLES: $\pm 2$ DEGREES FRACTIONS $\pm 1/16$ .X $\pm .125$ .XX $\pm .063$ .XXX $\pm .032$	MATERIAL: See Table FINISH: Natural
THIRD ANGLE PROJECTION	REVISION
	D
	SHEET SIZE
	A

 <b>Three M Tool</b> 1038 Elm Street York, PA 17403 Phone: 717-854-6379 Fax: 717-845-5232 www.ThreeMTool.com	PART DESCRIPTION
	<b>Reclaimer Screen</b> Empire Abrasive Equipment
	PART NUMBER
	EAE-739041-XX
	SCALE: NONE
	SHEET 1 OF 1