

	DATE	BY	REVISION
A	10/24/2017	KPV	INITIAL DESIGN

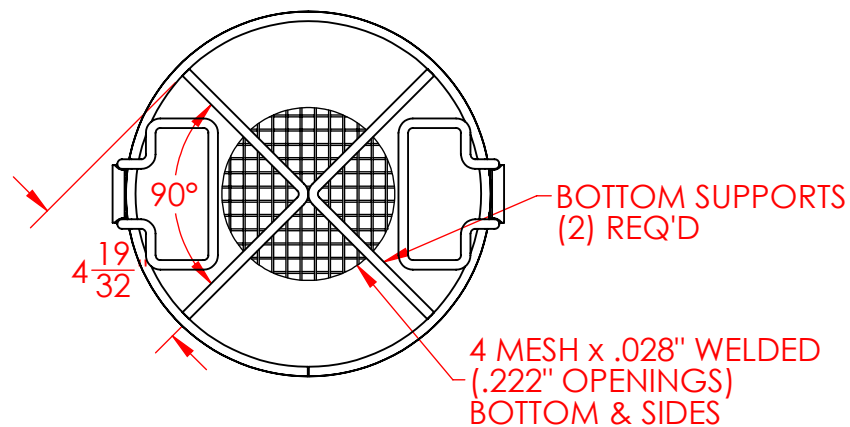
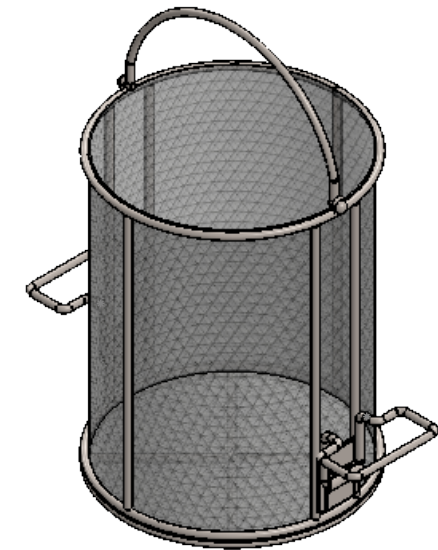
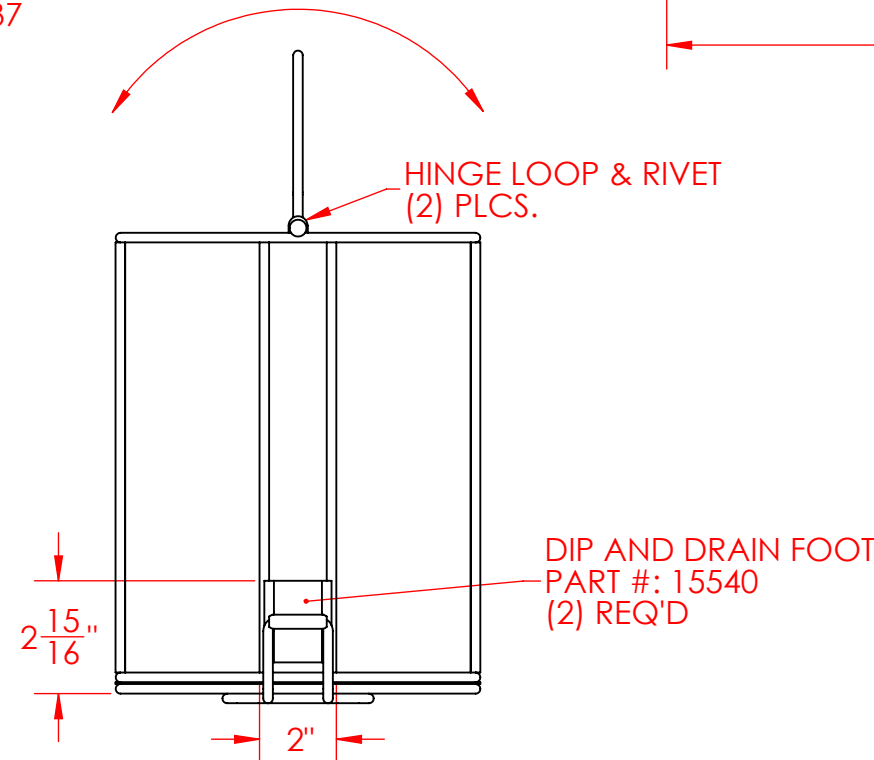
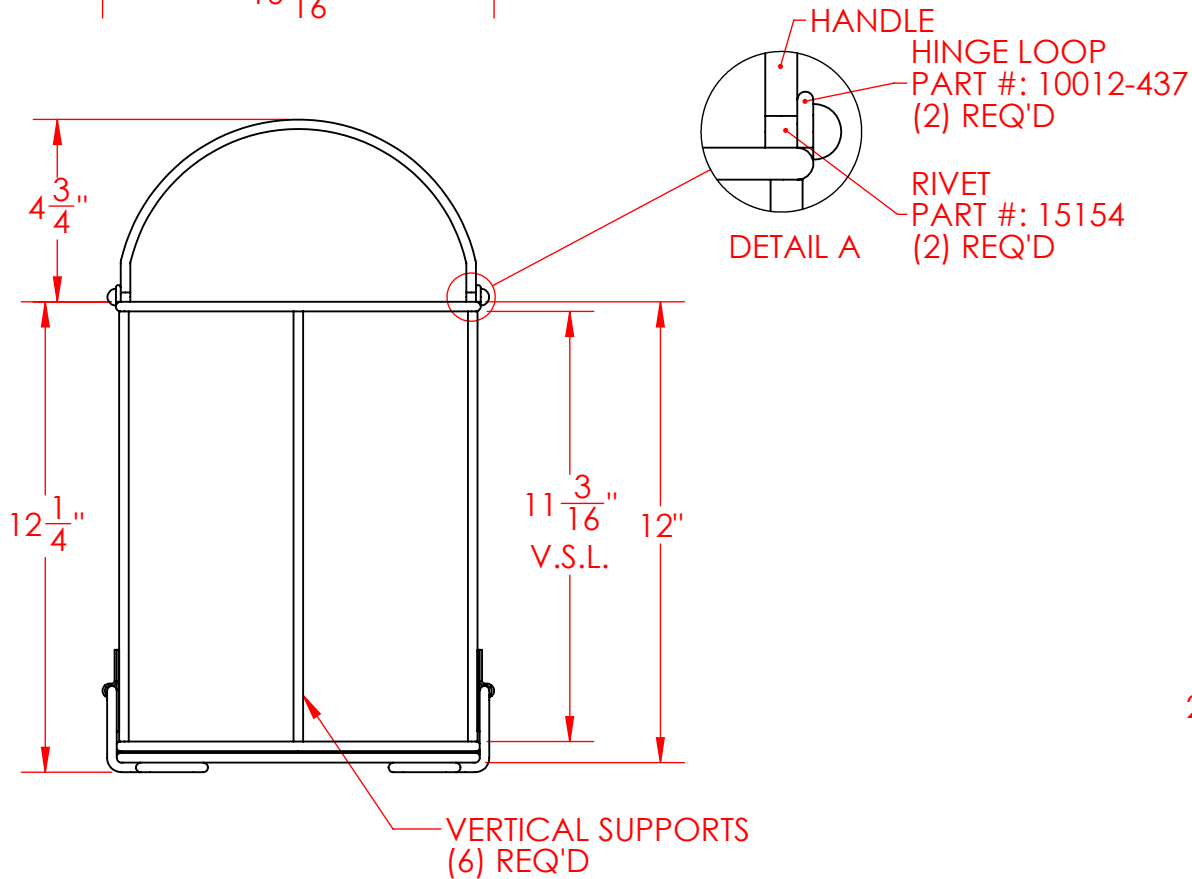
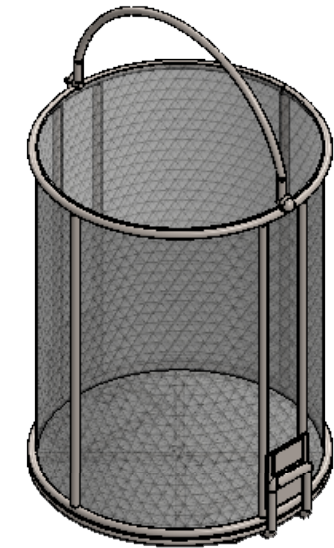
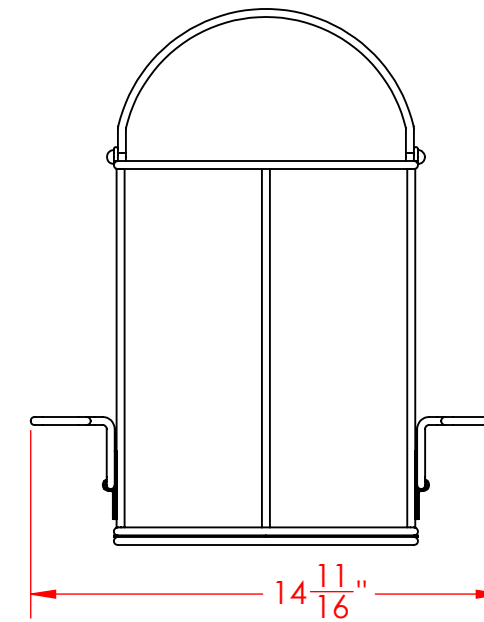
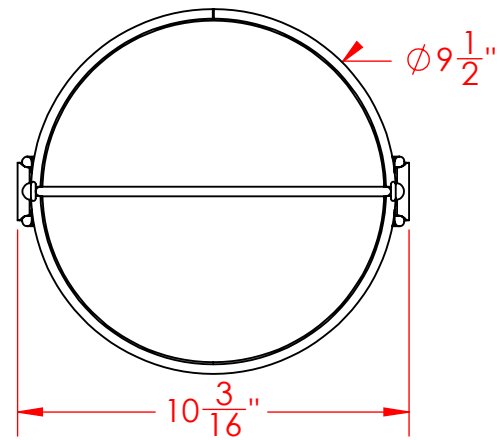

- NOTE:
1. ALL ROD TO BE $\phi 1/4''$ UNLESS OTHERWISE NOTED
 2. WIRE BRUSH TO REMOVE T.I.G. WELD DISCOLORATION
 3. DESIGNED FOR USE w/ A 5 GALLON BUCKET

MATERIAL: 304 SS

FINISH: NATURAL

TOLERANCES UNLESS NOTED OTHERWISE
 ANGLES: ± 2 DEGREES
 FRACTIONS $\pm 1/16$
 .X $\pm .125$
 .XX $\pm .063$
 .XXX $\pm .032$

THIRD ANGLE PROJECTION



SCALE: 1:5
 SHEET 1 OF 2

THE INFORMATION CONTAINED ON THIS DOCUMENT IS THE INTELLECTUAL PROPERTY OF THREE M TOOL AND MAY NOT BE COPIED OR DISCLOSED WITHOUT PRIOR WRITTEN PERMISSION FROM THREE M TOOL.

REVISION SHEET SIZE

A B

TMT Three M Tool
 1038 Elm Street
 York, PA 17403
 Phone: 717-854-6379
 Fax: 717-845-5232
 www.ThreeMTool.com

PART DESCRIPTION
Dip & Drain Basket w/ Swinging Round Loop Handle, Without Bucket
 Three M Tool
 PART NUMBER

DND-095RND120-C04S